



Hydraulic motorised furling systems brings ease of use to sailing handing on yachts 42' and over. The Facnor HF range is suitable for yachts unto 72' often equipped with other hydraulic devices.

photo credit : MichaelSchmidtYachtBau / explorer

**THE HYDRAULIC MOTORIZATION: POWER & TORQUE**

HF Hydraulic

- Plugged on standard hydraulic devices (max 140 bars\*)
- Durable drive unit, waterproof and compact, low noise level
- Power ratio / Optimum torque
- Installation on existing forestay
- Compact : reduced lateral dimensions compared with a classic drum
- Quick installation : split foot (HF700) + internal turnbuckle fitting
- No specific maintenance. International 3-year warranty

\*See chart against. In case of debit higher than the recommended one, please contact one agent. A debit control will be needed.

**Special aluminium cover**

Strong drive unit

**Anticorrosion surface treatment**

increased durability

**3 compact models**

from 42 to 72'



42 → 60'  
HF500 & 600



60 → 72'  
(HF700)

**Installation over existing forestay**

Passing through the drive unit.

**Reduced lateral dimensions**

(increased space for anchoring)

**Specific to HF700 : removable split polished base** for easy installation and access to the turnbuckle without dismantling forestay.

**SX foil sections** Capacity to support high level torques

**Back up device**

situated on starboard for emergency handling (or the Facnor emergency continuous line system).



(after use, screw the cap back)



HYDRAULIC MOTORISED RANGE

Technical datas :

Option : wired or radio remote control (see page 20)

Boat Length	Max forestay $\varnothing$	Section / Swivel	Model ref.	Forestay length	hydraulic connections	Max recommended / pressure (bars)	Max recommended / flow (L/min)	Max. rotation speed (RPM <sup>1</sup> /mn)
14 → 18 m 42' → 54'	14*	SX47 / C47	HF550	18 m 50	9/16"	125 (140 max)	15 (20 max)	30
				20 m 50				
18 → 20 m 54' → 60'	19*	SX53 / C600	HF600	22 m 50				
				24 m 50				
20 → 24 m 60' → 72'	22* /#76*		HF700	28 m 50	G3/8'	(140 max)	60	24
				30 m 50				
40 → 50 m 131' → 164'	40*	$\varnothing$ 105 / C105	HF950	50 m				

RPM<sup>1</sup> : Rotations per Minute

\*Installation with swage rigging screw or "manual"

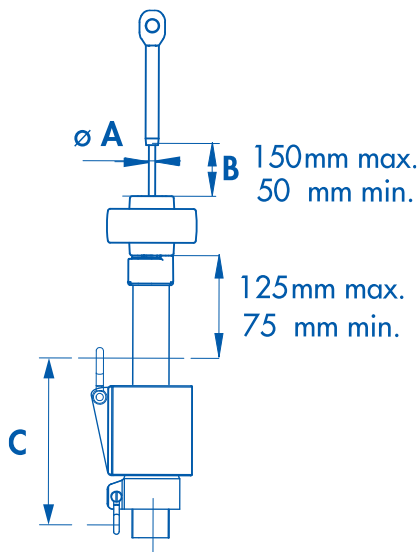

**Stainless steel toggle & link plates**

- Fitted according to bottom forestay terminal (turnbuckle + toggle or eye + toggle). Toggle and stainless steel link plates are delivered in the standard kit.

**HF Sections :**

- Standard SX47 & SX53 foil sections are common to all systems.

HF DIMENSIONS

Rep.	HF 550	HF 600	HF 700
Section / Swivel Ref.	SX 47 C47	SX 53 C600	SX 53 C600
A = max. forestay $\varnothing$ (* turnbuckle)	14 mm*	19 mm*	22 mm* #76*
B	53	53	52
C	220	228	228
D*	106	103	123
E	248	263	325
F	77	82	100
G	536*	770	495
M4	216	267	267
$\varnothing K$	72	72	85
$\varnothing L$	70	72	85
M1	146	146	162
M2	16	172	177
M3	185	324	292
P	106	103	123
Q	485	435	686
R	89	265	158
$\varnothing S$	50	53	64
T	75	78	90

